

### Description

The GM66100/1/2 series are 1A ultra low-dropout linear voltage regulators that provide low-voltage, high output current from an extremely small package.

The GM66100/1/2 offers extremely low dropout (typically 410 mV at 1A) and low ground current (typically 12mA at 1A).

The GM66100 offers 3 Lead packages with a fixed output voltage options while GM66101/2 offer SO8 packages for fixed and adjustable output voltages accordingly.

The GM66100/1/2 is ideal for PC add-in cards that need to convert from standard 5V to 3.3V, 3.3V to 2.5V or 2.5V to 1.8V. A guaranteed maximum dropout voltage of 630mV over all operating conditions allows the GM66100/1/2 provide 2.5V from a supply as low as 3.13V and 1.8V from a supply as low as 2.43V.

The GM66100/1/2 is fully protected with over current limiting, thermal shutdown, and reversed-battery protection.

### Features

- ◆ Fixed and adjustable output voltages
- ◆ Typical 410mV Dropout Voltage @ 1A
- ◆ 1A minimum guaranteed output current
- ◆ Accurate 1% Guaranteed Tolerance
- ◆ Current limiting and thermal shutdown
- ◆ Reverse-battery Protection
- ◆ Reversed leakage protection
- ◆ Fast Transient Response

### Application

High Efficiency Linear Regulators

Ideal for 3.0V to 2.5V conversion

Ideal for 2.5V to 1.8V conversion

Battery Powered Equipment

Automotive Electronics

Post Regulators for Switching Supplies

### Typical Application Circuits

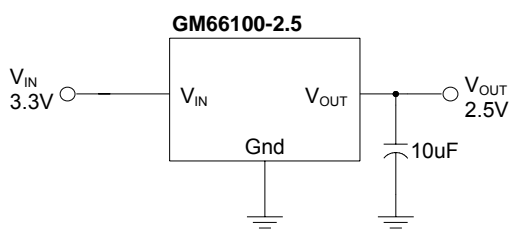

2.5V/1A Regulator

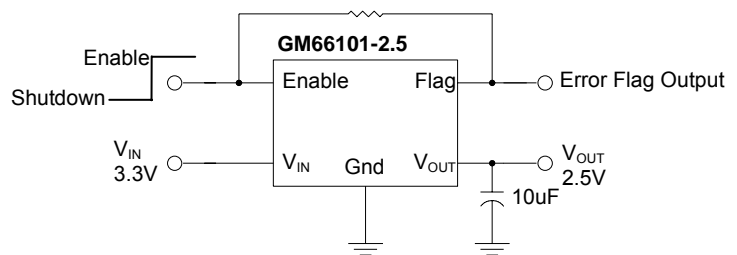

2.5V/1A Regulator with Error Flag

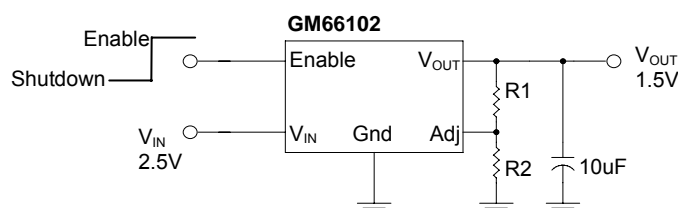

1.5V/1A Adjustable Regulator

## Marking Information and Pin Configurations (Top View)

### GM66100

TO 252  
(D-PAK)

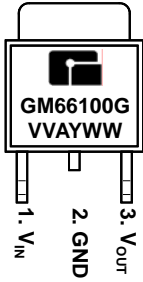

TO 263  
(D<sup>2</sup>-PAK)

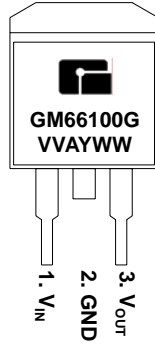

TO 220

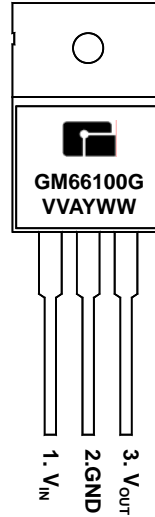

SOT223

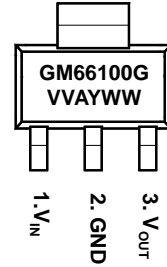

G: Green Product  
 VV: Fixed Output (15 = 1.5V, 25 = 3.3V...)  
 A: Assembly / Test site code  
 Y: Year  
 WW: Week

### GM66101

S08

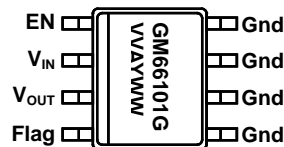

G: Green Product  
 VV: Fixed Output (15 = 1.5V, 25 = 3.3V...)  
 A: Assembly / Test site code  
 Y: Year  
 WW: Week

### GM66102

S08

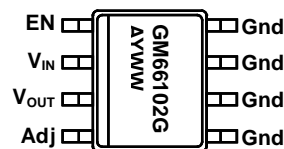

G: Green Product  
 A: Assembly / Test site code  
 Y: Year  
 WW: Week

### Ordering Information

Ordering Number	Output Voltage	Package	Shipping
<b>GM66100</b>			
GM66100-1.8TA3RG	1.8V	TO-263	800 Units / Reel
GM66100-1.8TB3TG	1.8V	TO-220	50 Units/Tube
GM66100-1.8TC3TG	1.8V	TO-252	2,500 Units/Reel
GM66100-1.8ST3RG	1.8V	SOT-223	2,500 Units/Reel
GM66100-2.5TA3RG	2.5V	TO-263	800 Units / Reel
GM66100-2.5TB3TG	2.5V	TO-220	50 Units/Tube
GM66100-2.5TC3RG	2.5V	TO-252	2,500 Units / Reel
GM66100-2.5ST3RG	2.5V	SOT223	2,500 Units / Reel
GM66100-3.3TA3RG	3.3V	TO-263	800 Units / Reel
GM66100-3.3TB3TG	3.3V	TO-220	50 Units/Tube
GM66100-3.3TC3TG	3.3V	TO-252	2,500 Units/Reel
GM66100-3.3ST3RG	3.3V	SOT-223	2,500 Units/Reel
GM66100-5.0TA3RG	5.0V	TO-263	800 Units / Reel
GM66100-5.0TB3TG	5.0V	TO-220	50 Units/Tube
GM66100-5.0TC3RG	5.0V	TO-252	2,500 Units / Reel
GM66100-5.0ST3RG	5.0V	SOT223	2,500 Units / Reel

### Ordering Information (continued)

Ordering Number	Output Voltage	Package	Shipping
<b>GM66101</b>			
GM66101-1.8S8RG	1.8V	SOP-8	2,500 Units/Reel
GM66101-2.5S8RG	2.5V	SOP-8	2,500 Units/Reel
GM66101-3.3S8RG	3.3V	SOP-8	2,500 Units/Reel

### Ordering Information (continued)

Ordering Number	Output Voltage	Package	Shipping
<b>GM66102</b>			
GM66102S8RG	Adj	SOP-8	2,500 Units/Reel

### Absolute Maximum Ratings (Note 1)

Rating	Symbol	Value	Unit
Supply Voltage	$V_{IN}$	-20 to +20	V
Enable Voltage	$V_{EN}$	+20	V
Storage Temperature Range	$T_{STG}$	- 65 to 150	°C
Lead Temperature (Soldering, 10 sec)		+ 260	°C
ESD		<b>Note 3</b>	

### Operating Ratings (Note 2)

Rating	Symbol	Value	Unit
Supply Voltage	$V_{IN}$	2.25 to 16	V
Enable Voltage	$V_{EN}$	2.25 to 16	V
Maximum Power Dissipation	$P_{D(MAX)}$	<b>Note 4</b>	
Junction Temperature Range	$T_J$	-40 to 125	°C
Package Thermal Resistances	SOT223	$\theta_{JC}$	15 °C/W
	SO8		20 °C/W

### Block Diagram

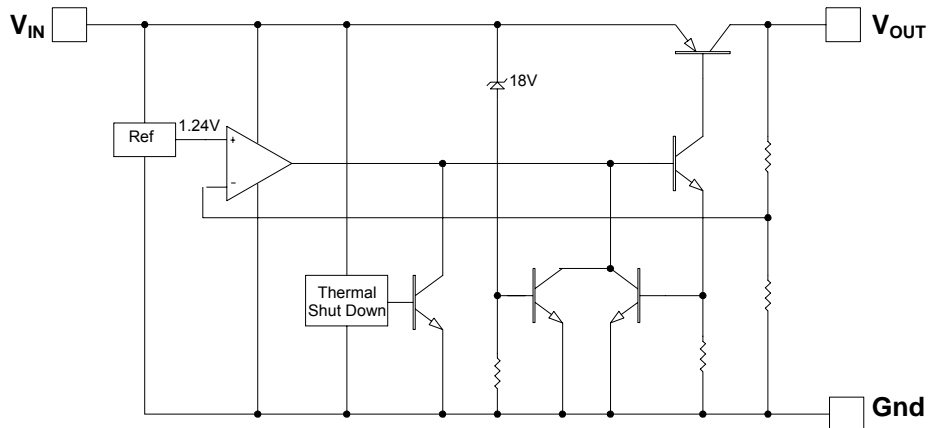

GM66100 Fixed Regulator Block Diagram

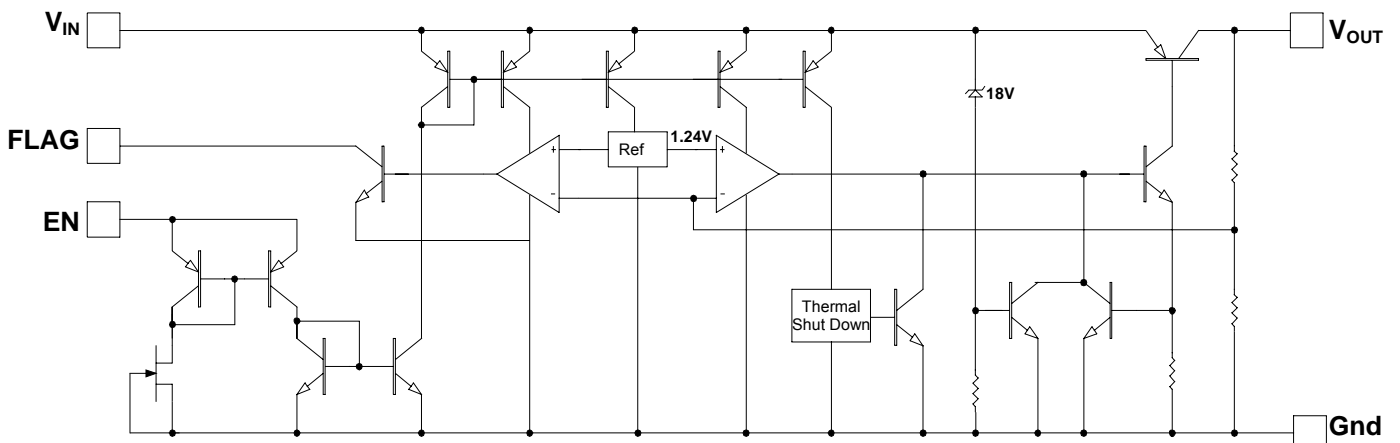

GM66101 Fixed Regulator with Flag and Enable Block Diagram

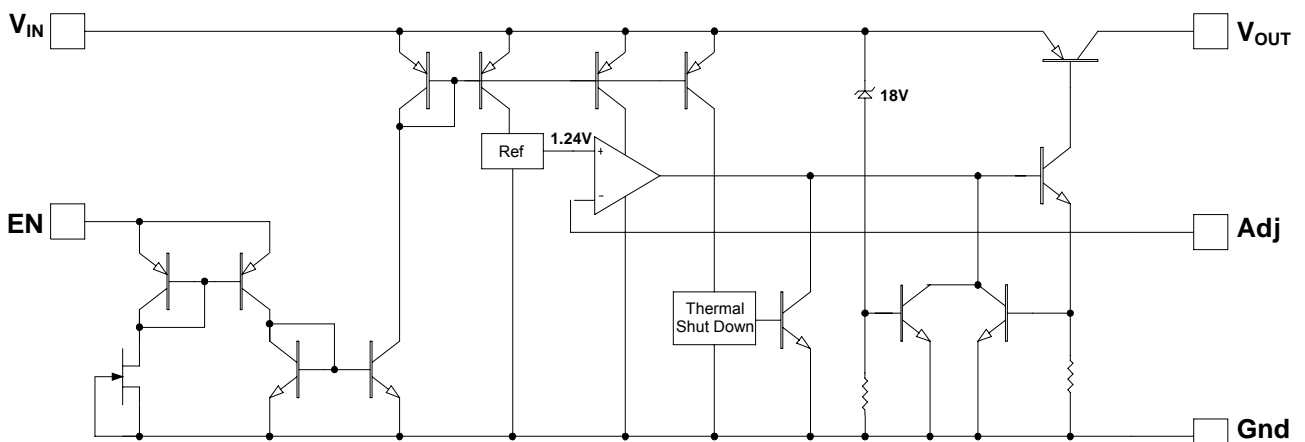

GM66102 Adjustable Regulator with Enable Block Diagram

### Electrical Characteristics:

( $V_{IN} = V_{OUT} + 1V$ ,  $V_{EN} = 2.25V$ , Unless otherwise specified:  $T_J = 25^\circ C$ , Bold values are guaranteed across the full operating temperature range)

Parameter	Condition	Symbol	Min	Typ	Max	Unit
Output Voltage	$I_O = 10mA$	$V_{OUT}$	-1		1	%
	$10mA \leq I_O \leq 1A$ , $V_{OUT} + 1V \leq V_{IN} \leq 8V$		-2		-2	
Line Regulation	$I_O = 10mA$ , $V_{OUT} + 1V \leq V_{IN} \leq 16V$	$\Delta V_{OI}$		0.06	0.5	%
Load Regulation	$V_{IN} = V_{OUT} + 1V$ , $10mA \leq I_O \leq 1A$	$\Delta V_{OL}$		0.2	1.0	%
Output Temperature Coefficient	<b>Note 5</b>	$\Delta V_{OUT} / \Delta T$		40	100	ppm/ $^\circ C$
Dropout Voltage, <b>Note 6</b>	$I_O = 100mA$ , $\Delta V_{OI} = -1\%$	$V_{DO}$		150	200	mV
	$I_O = 500mA$ , $\Delta V_{OI} = -1\%$			275	<b>250</b>	
	$I_O = 750mA$ , $\Delta V_{OI} = -1\%$			330	500	
	$I_O = 1A$ , $\Delta V_{OI} = -1\%$			410	<b>550</b>	
Ground Current <b>Note 7</b>	$I_O = 100mA$ , $V_{IN} = V_{OUT} + 1V$	$I_{GND}$		700		$\mu A$
	$I_O = 500mA$ , $V_{IN} = V_{OUT} + 1V$			4		mA
	$I_O = 750mA$ , $V_{IN} = V_{OUT} + 1V$			7		
	$I_O = 1A$ , $V_{IN} = V_{OUT} + 1V$			12	<b>20</b>	
Current Limit	$V_{OUT} = 0V$ , $V_{IN} = V_{OUT} + 1V$	$I_{CL}$		1.8	2.5	A

### Enable Input

Parameter	Condition	Symbol	Min	Typ	Max	Unit
Enable Input Voltage	Logic low (OFF)	$V_{EN(low)}$			0.8	V
	Logic High (ON)	$V_{EN(high)}$	2.25			
Enable Input Current	$V_{EN} = 2.25V$	$I_{EN(low)}$	1	15	30	$\mu A$
					<b>75</b>	
	$V_{EN} = 0.8V$	$I_{EN(high)}$			2	
					<b>4</b>	

### Flag Output

Parameter	Condition	Symbol	Min	Typ	Max	Unit
Output Leakage Current	$V_{OH} = 16V$	$I_{FLG(Leak)}$		0.01	1	$\mu A$
					2	
Output Low Voltage <b>Note 8</b>	$V_{IN} = 0.9V + V_{OUT\ Nominal}, I_{CL} = 250\mu A$	$V_{FLG(DO)}$		240	300	mV
					<b>400</b>	
Low Threshold	% of $V_{OUT}$		93			%
High Threshold	% of $V_{OUT}$				<b>99.2</b>	
Hysteresis				1		
Enable Input Current		$I_{EN(low)}$	1	15	30	$\mu A$
					<b>75</b>	
	$V_{EN} = 0.8V$	$I_{EN(high)}$			2	
					<b>4</b>	

### GM66102 Only

Parameter	Condition	Symbol	Min	Typ	Max	Unit
Reference Voltage		$V_{REF}$	1.228	1.24	1.252	V
			<b>1.215</b>		<b>1.265</b>	
	<b>Note 9</b>		<b>1.203</b>		<b>1.277</b>	
Adjust Pin Bias Current		$I_{ADJ}$		40	80	$\mu A$
					<b>120</b>	
Reference Voltage Temp Coefficient <b>Note 5</b>		$\Delta V_{REF} / \Delta T$		20		ppm/ $^{\circ}C$
Adjust Pin Bias Current Temp Coefficient		$\Delta I_{ADJ} / \Delta T$		0.1	99.2	nA/ $^{\circ}C$

Note 1: Exceeding the absolute maximum ratings may damage the device.

Note 2: The device is not guaranteed to function outside its operating rating.

Note 3: Devices are ESD sensitive. Handling precautions is recommended.

Note 4:  $P_{D(MAX)} = (T_{J(MAX)} - T_A) / \theta_{JA}$ , where  $\theta_{JA}$  is junction to ambient thermal resistance

Note 5: Output voltage temperature coefficient is  $\Delta V_{OUT(worst\ case)} / (T_{J(MAX)} - T_{J(MIN)})$ , where  $T_{J(MAX)}$  is  $125^{\circ}C$  and  $T_{J(MIN)}$  is  $0^{\circ}C$

Note 6:  $V_{DO} = V_{IN} - V_{OUT}$  when  $V_{OUT}$  decreases to 99% of its nominal output voltage with  $V_{IN} = V_{OUT} + 1V$ . For output voltage below 2.25V, dropout voltage is the input-to-output voltage differential with the minimum input voltage being 2.25V. Minimum input operating voltage is 2.25V.

Note 7:  $I_{GND}$  is the quiescent current.  $I_{IN} = I_{GND} + I_{OUT}$

Note 8: For adjustable device and fixed device with  $V_{OUT} \geq 2.5V$

Note 9:  $V_{REF} \leq V_{OUT} \leq (V_{IN} - 1V)$ ,  $2.25V \leq V_{IN} \leq 16V$ ,  $10mA \leq I_L \leq 1A$

### Application Information

The GM66100/1/2 is a low dropout voltage regulator suitable for applications which ultra low dropout performance is needed. Unlike older NPN-pass transistor designs, where the minimum dropout voltage is limited by the base-to-emitter voltage drop and collector-to-emitter saturation voltage, dropout performance of the PNP output of these devices is limited only by the low  $V_{CE}$  saturation voltage.

The GM66100/1/2 regulator is fully protected from damage due to fault conditions. Linear current limiting is provided. Output current during overload conditions is constant. Thermal shutdown disables the device when the die temperature exceeds the maximum safe operating temperature. Transient protection allows device (and load) survival even when the input voltage spikes above and below nominal. The output structure of these regulators allows voltages in excess of the desired output voltage to be applied without reverse current flow.

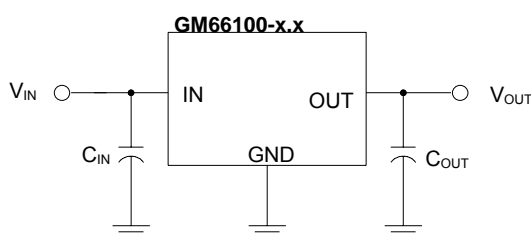

**Figure 1. Capacitor Requirements**

#### Output Capacitor

An output capacitor is required for the GM66100/1/2 to maintain stability and improve transient response. Proper capacitor selection is important to ensure proper operation. The output capacitor selection is dependent upon the ESR (equivalent series resistance) of the output capacitor to maintain stability.

When the output capacitor is 10 $\mu$ F or greater, the ESR value of the output capacitor should be less than 2 $\Omega$  for the purpose of transient response improvement as well as stability. Ultra-low-ESR capacitors (<100m $\Omega$ ), such as ceramic chip capacitors, may promote instability. A low-ESR solid tantalum capacitor works extremely well and provides good transient response and stability over temperature. Aluminum electrolytes can also be used, as long as the ESR of the capacitor is <2 $\Omega$ .

The value of the output capacitor can be increased without limit. Higher capacitance values help to improve transient response and ripple rejection and reduce output noise.

#### Input Capacitor

An input capacitor of 1 $\mu$ F or greater is recommended when the device is more than 4 inches away from the bulk ac supply capacitance or when the supply is a battery. Small, surface mount, ceramic chip capacitors can be used for bypassing. Larger values will help to improve ripple rejection by bypassing the input to the regulator, further improving the integrity of the output voltage.

#### Error Flag

The GM66101 features an error flag (FLG), which monitors the output voltage and sends out an error signal when the output voltage drops 5% below its expected value. The error flag is an open-collector output that pulls low under fault conditions and may sink up to 10mA. Low output voltage signifies a number of possible problems, including an over current fault (the device is in current limit) or low input voltage. The flag output is inoperative during over temperature conditions. A pull-up resistor from FLG to either  $V_{IN}$  or  $V_{OUT}$  is required for proper operation. For information regarding the minimum and maximum values of pull-up resistance, refer to the graph in the typical characteristics section of the data sheet.

### Enable Input

The GM66101 and GM66102 feature an active-high enable input (EN) which allows on-off control of the regulator. The EN input has TTL/CMOS compatible thresholds for simple logic interfacing. EN may be directly tied to  $V_{IN}$  and pulled up to the maximum supply voltage.

### Transient Response and 3.3V to 2.5V or 2.5V to 1.8V Conversion

The GM66100 series has excellent transient response to variations input voltage and load current. The device has been designed to respond quickly to load current variations and input voltage variations. Large output capacitors are not required to obtain this performance. A standard 10 $\mu$ F output capacitor, preferably tantalum, is all that is required. Larger values help to improve performance even further.

By virtue of its low-dropout voltage, this device does not saturate into dropout as readily as similar NPN-based designs. When converting from 3.3V to 2.5V or 2.5V to 1.8V, the NPN based regulators are already operating in dropout, with typical dropout requirements of 1.2V or greater. To convert down to 2.5V or 1.8V without operating in dropout, NPN based regulators require an input voltage of 3.7V at the very least.

The GM66100 regulator will provide excellent performance with an input as low as 3.0V or 2.5V respectively. This gives the PNP based regulators a distinct advantage over older, NPN based linear regulators.

### Minimum Load Current

The GM66100/1/2 regulator is specified between finite loads. If the output current is too small, leakage currents dominate and the output voltage rises. A 10mA minimum load current is necessary for proper regulation.

### Adjustable Regulator Design

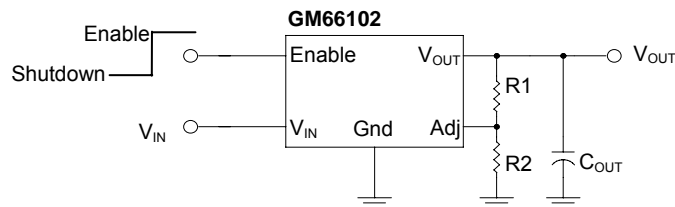

**Figure 2. Adjustable Regulator with Resistors**

$$V_{OUT} = 1.24V \times (1 + R1/R2)$$

The GM66102 allows programming the output voltage anywhere between 1.24V and the 16V maximum operating rating of the family. Two resistors are used. The resistor values are calculated by:

$$R1 = R2 \times (V_{OUT}/1.24 - 1)$$

Where  $V_{OUT}$  is the desired output voltage. Figure 2 shows component definition. Applications with widely varying load currents may scale the resistors to draw the minimum load current required for proper operation (see above).

### Package Outline Dimensions – SOT223

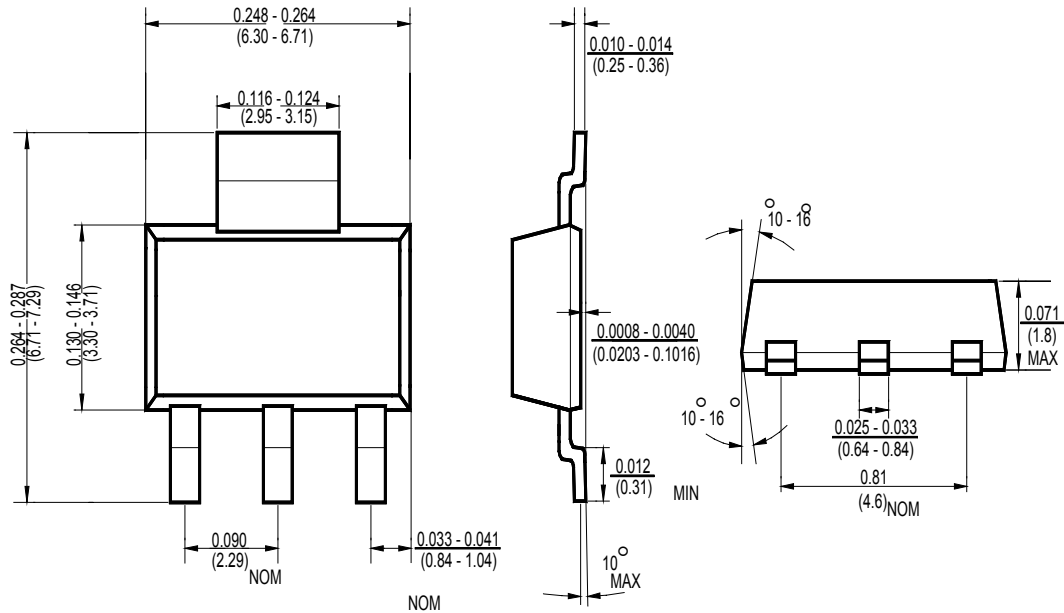

### Package Outline Dimensions – TO252

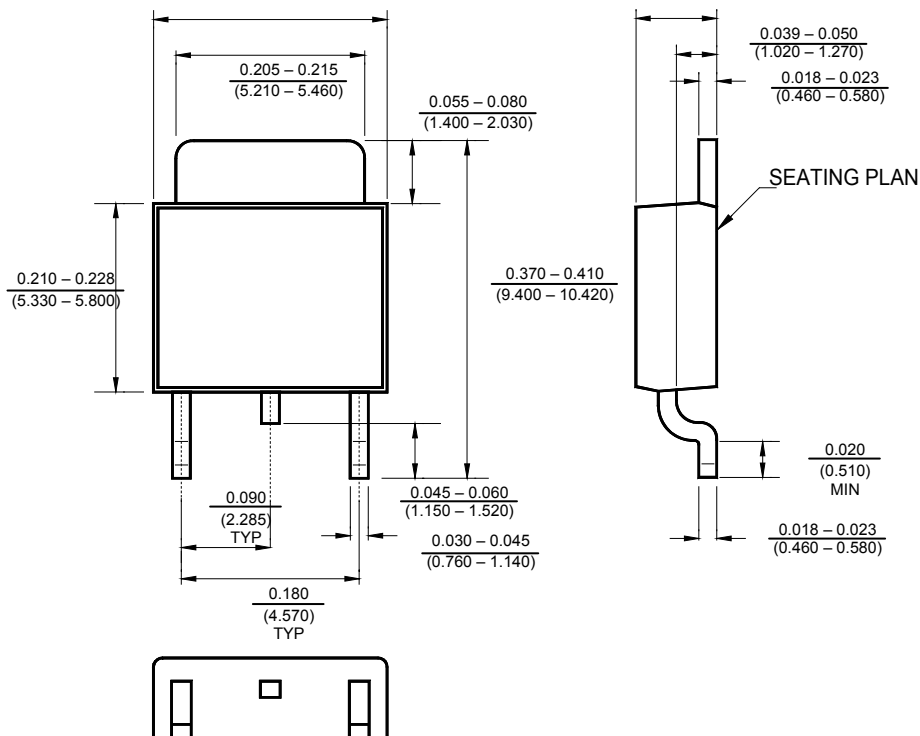

### Package Outline Dimensions – TO263

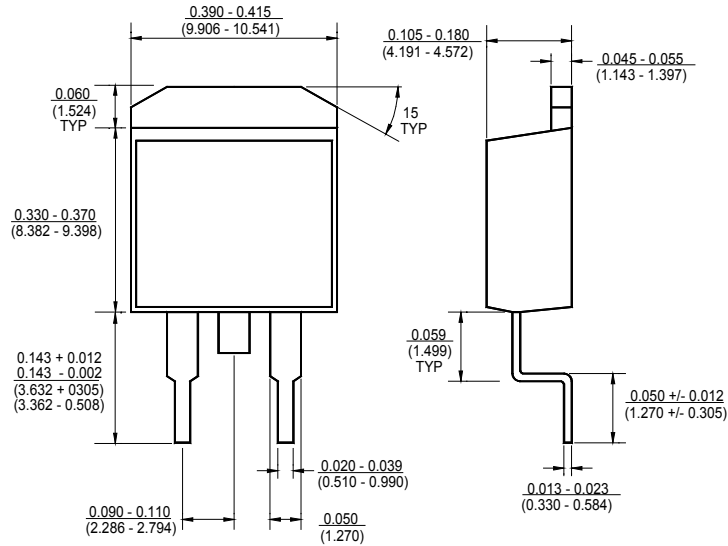

### Package Outline Dimensions – SO 8

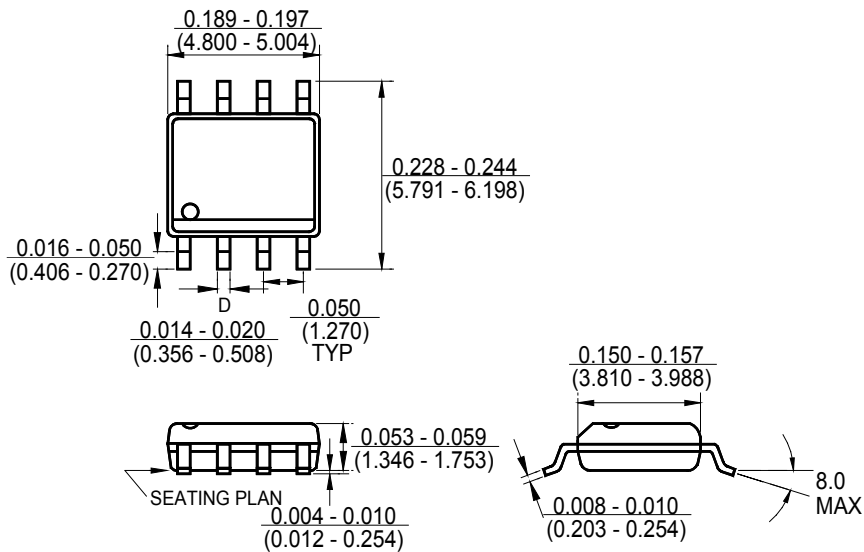

## Ordering Number

<b><u>GM 66100</u> -1.8</b>		<b><u>TA3</u></b>	<b><u>R</u></b>	<b><u>G</u></b>
APM Gamma Micro	Circuit Type	Output Voltage	Package Type	Shipping Type
		1.8 = 1.8V 2.5 = 2.5V 3.3 = 3.3V 5.0 = 5.0V	TA3: TO263 TB3: TO220 TC3: TO252 ST3: SOT223	R:Taping & Reel T: Tube Blank: Pb-free G:Green

<b><u>GM 66101</u> -1.8</b>		<b><u>S8</u></b>	<b><u>R</u></b>	<b><u>G</u></b>
APM Gamma Micro	Circuit Type	Output Voltage	Package Type	Shipping Type
		1.8 = 1.8V 2.5 = 2.5V 3.3 = 3.3V 5.0 = 5.0V	S8: SOP-8	R:Taping & Reel T:Tube Blank: Pb-free G:Green

<b><u>GM 66102</u></b>		<b><u>S8</u></b>	<b><u>R</u></b>	<b><u>G</u></b>
APM Gamma Micro	Circuit Type	Output Voltage	Package Type	Shipping Type
		Adj	S8: SOP-8	R:Taping & Reel T:Tube Blank: Pb-free G:Green

Note:

### Pb-free products:

- ◆ RoHS compliant and compatible with the current requirements of IPC/JEDEC J-STD-020.
- ◆ Suitable for use in Pb-free soldering processes with 100% matte tin (Sn) plating.

### Green products:

- ◆ Lead-free (RoHS compliant)
- ◆ Halogen free (Br or Cl does not exceed 900ppm by weight in homogeneous material and total of Br and Cl does not exceed 1500ppm by weight)